

*S*tudiomaster

VORTEX10A/VORTEX12A



**USER
GUIDE**

Introduction:

"VORTEX" series currently varies in both 10" and 12", featuring the latest electro-acoustic and electronic design. Accurate sound is delivered from coaxial driver arrangement in this most economical product of STUDIOMASTER. The woofer is designed with ferrite magnetic circuit, and the voice coil is made of new heat-resistant material offering an extraordinary heat dissipation capability at high power output; the tweeter is a compressed driver with AL diaphragm for bright and penetrating tone; the amplifier preamp input uses a 24bit 48kHz DSP processor on which four sound modes selection, 3-band equalization, low-cut, pressure limit, delay, volume control and other functions are available on LCD display for easy adjustment of each function parameter. In addition, the bass uses Class-D audio power amplification and the MF uses Class-AB audio power amplification, which have the advantages of high efficiency, small size, high power, light weight, stable performance, and amazing sound.

Feature:

1. Made of high-strength polypropylene engineering plastic injection moulded.
2. Woofer and tweeter are designed with ferrite magnetic circuit, ensuring high sensitivity, low distortion, high power and high efficiency.
3. Dual amplifier circuit, bass Class-D + MF Class-AB amplifier, Amplifier power 300W + 50W; wide power supply design for global use.
4. 24bit 48kHz DSP processor with LCD display for adjusting sound effects, 3-band equalization, low cut, voltage limit, delay, volume control and other functions.
5. 2 handles, more convenient to carry, light weight, noble and elegant appearance.
6. 45 degree wedge design, can also be used as a monitor speaker.
7. Fixed installation (35mm support hole), double-hole tray for 0° and 7.5°
8. Hanging installation (5*M10 flying points).

Application:

Ideal for large, medium and small conference rooms, classrooms, stations, shopping malls, etc.

SAFETY INSTRUCTIONS

READ THIS BEFORE YOU USE THIS PRODUCT

1. Before connecting the A.C. power cord make sure the Voltage Selector is set for your local A.C. supply voltage.
2. Only use the A.C. power cord / mains lead supplied with this product. Replace if it becomes damaged in any way.
3. Never operate without, or remove the safety ground (earth) from the A.C. Power cord/mains lead.
4. Do not attempt to remove any screws or panels. There are no user serviceable parts inside.
5. Do not operate the unit next to heat sources such as radiators.
6. The unit should not be operated or stored near rain or moisture.
7. This equipment must not be exposed to dripping or splashing and no objects filled with liquids should be placed on top of it.
8. Write the serial number in the box provided in the Warranty section for future reference.
9. If the unit gets damaged, has been dropped or appears to have developed a fault refer to the Service Information section for details.

WARNING: THIS APPARATUS MUST BE EARTHED (GROUNDED)



WEEE Mark

If you want to dispose of this product, do not mix with general household waste. There are separate collection systems for used electronic products in accordance with legislation under the WEEE Directive (Directive 2002/96/EC) and is effective only within the European Union.

Active panel(Fig2)

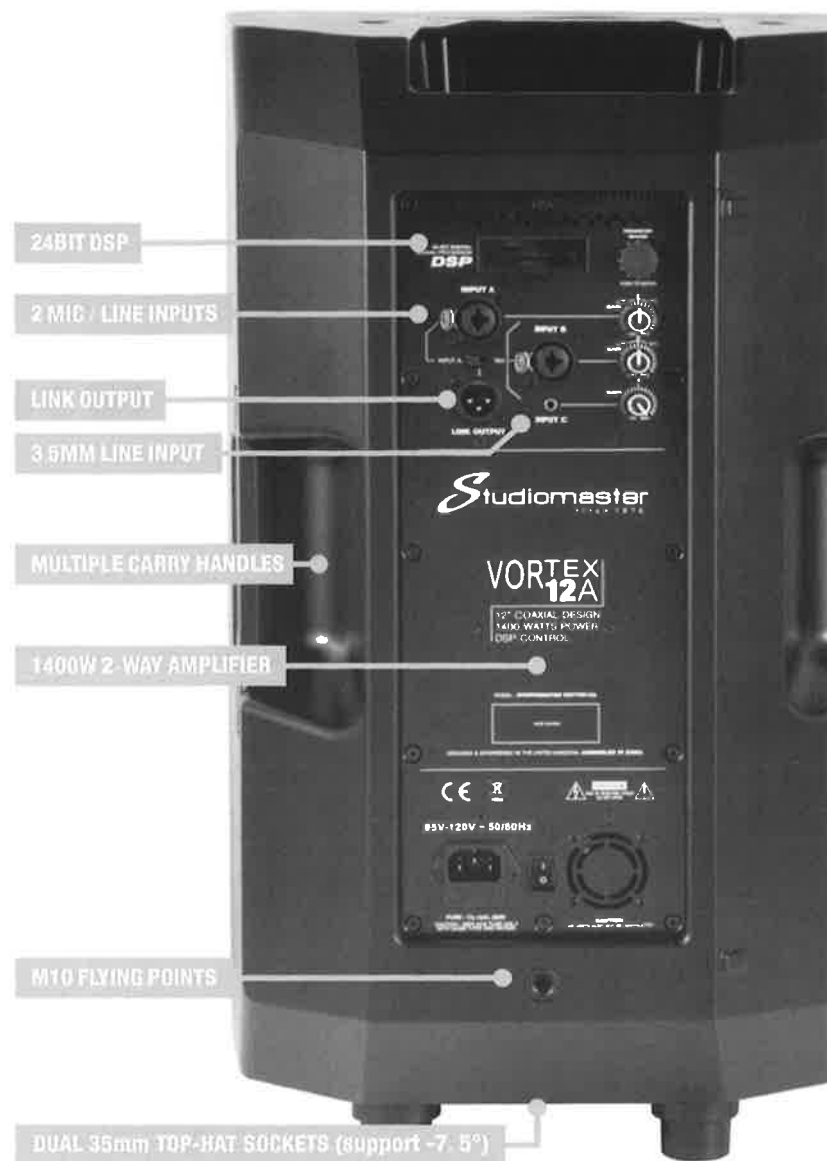

Wiring

- For 1/4" phone jack

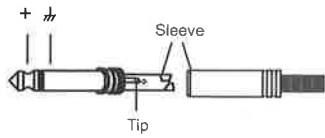

1/4" TS connector
Unbal input/output

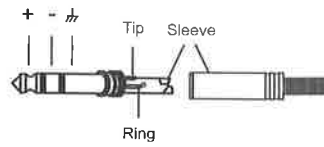

1/4" TRS connector
bal input/output

- For XLR

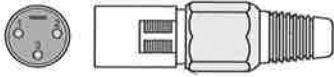

XLR (male)
Pin 2=+, Pin 3=-, Pin 1=ground

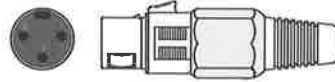

XLR (female)
Pin 2=+, Pin 3=-, Pin 1=ground

- For speaker connector



LF: 1+ 1-
HF: 2+ 2-

Speaker connection

- combo

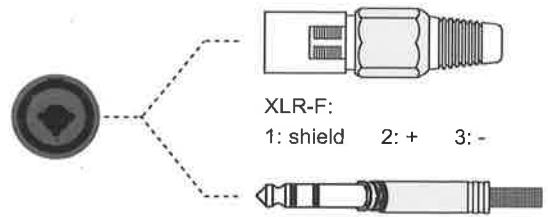

XLR-F:
1: shield 2: + 3: -

TRS
+/-/ground

combo -XLR connector

- For RCA

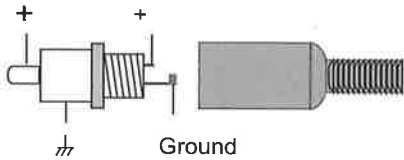

Specification

model	VORTEX10A
type	10" 2-way active coaxial plastic speaker
frequency response (-10dB)	60Hz--20KHz
input sensitivity LINE	0 dBu
MIC	-32dBu
max. SPL (dB)	124.5dB
AMP power	1400W
LF unit	10" woofer
HF unit	34 core compression driver/1" throat
coverage (V*H)	80°x80°
crossover frequency	2.2 kHz
input connection	2×JACK、XLR+JACK-3.5
DSP	5 modes (music/speech/live/DJ/monitor) , 3-band EQ, low-cut, delay, volume control,etc.
Bluetooth	bluetooth
input voltage	100V-240V(wide power supply)
support mount	35mm hole, with 0° and -7.5°optional
hanging mount	5×M10
dimension (W*H*D)	310×515×280 (mm)
weight	12.8 kg

model	VORTEX12A
type	12" 2-way active coaxial plastic speaker
frequency response (-10dB)	55Hz--20KHz
input sensitivity LINE	0 dBu
MIC	-32dBu
max. SPL (dB)	126.5dB
AMP power	1400W
LF unit	12" woofer
HF unit	34 core compression driver/1" throat
coverage (V*H)	80°x80°
crossover frequency	2.2 kHz
input connection	2×JACK、XLR+JACK-3.5
DSP	5 modes (music/speech/live/DJ/monitor) , 3-band EQ, low-cut, delay, volume control,etc.
Bluetooth	bluetooth
input voltage	100V-240V(wide power supply)
support mount	35mm hole, with 0° and -7.5°optional
hanging mount	5×M10
dimension (W*H*D)	360×585×310 (mm)
weight	15.3kg

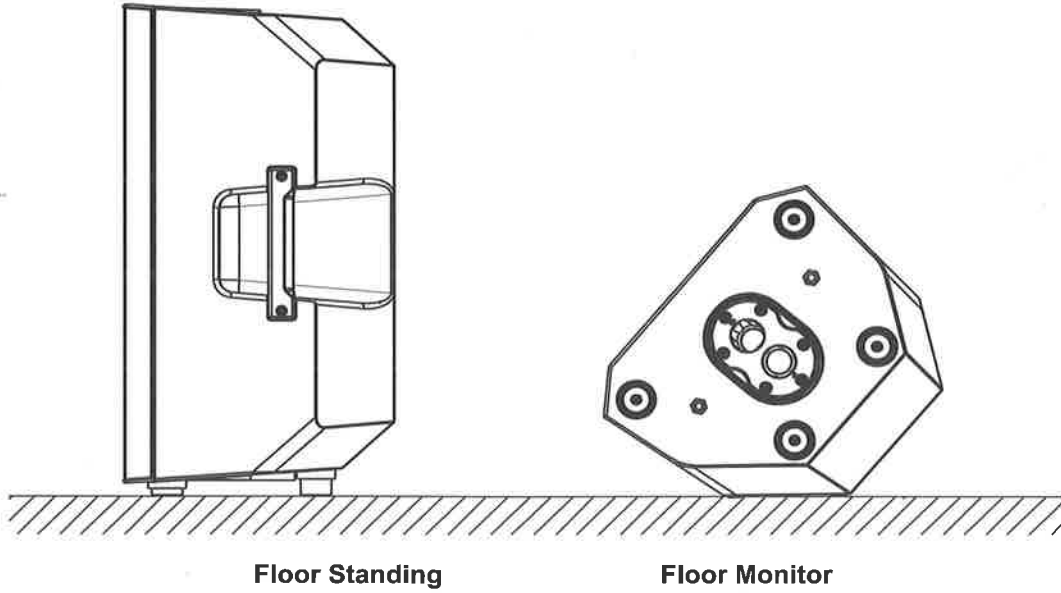

Accessories:

StuDiomaster also produces some optional accessories to match your system.
More detailed information, please see our website: www.stuDiomaster.com.

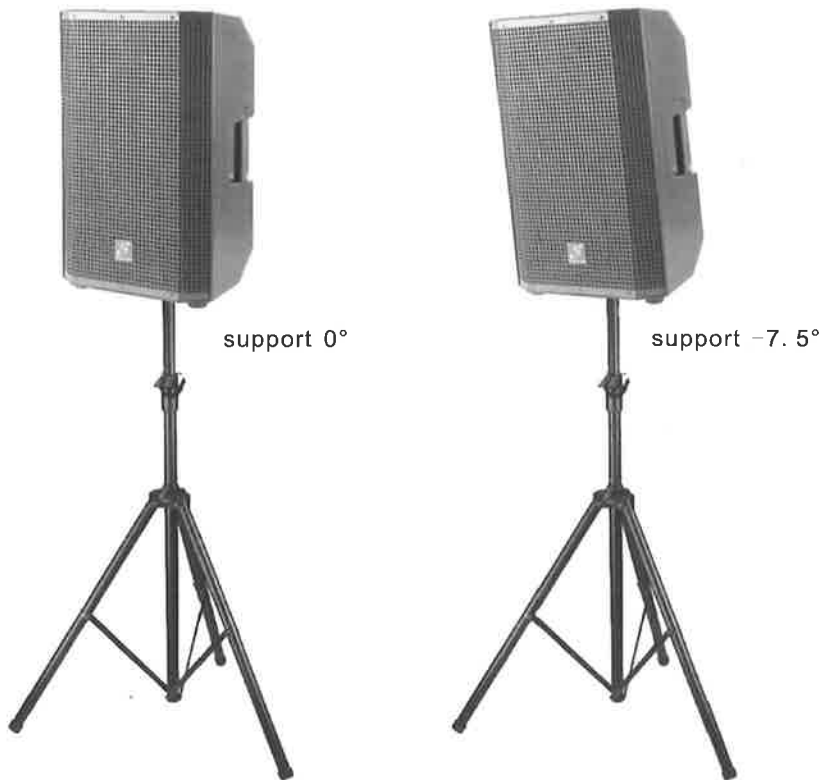

SERVICE INFORMATION

If you have a problem with your Studiomaster product or think it has developed a fault you should first carefully check the Trouble Shooting section in this guide. If this does not solve the problem or if the product is physically damaged, contact your local dealer or distributor for service details.

Should it be recommended you return the product to your nearest Studiomaster Service Centre you must first contact them.

You will be asked for the product type and serial number. You will then be given a returns Authorisation (RA) number.

Pack the unit in its original carton to protect it from shipping damage.

You must have the Returns Authorisation number clearly marked on the outside of the carton or we may refuse the delivery.

Studiomaster cannot be held responsible for damage resulting from the equipment being packed incorrectly.

Label the equipment clearly with your name and address and include a clear description of the fault. The more information you supply helps the service engineer, minimising repair cost when out of warranty.

Please write your serial number here for future reference.

Trouble shooting

Problem	Reason
Power LED does not light up	Check if the power cord is connected well? If power supply is ok? If the power switch is set to ON? If the amp fuse is broken?
No sound	If the system is connected well? if power supply is turned on? if signal input is ok?
Distortion	If the signal level is too high? If PEAK LED lights up? if the switch is released?
Abnormal tone	If system is connected well? if signal input is ok? if ground switch is released?
Insufficient SPL	If system is connected well? if volume knob (LEVEL/GAIN) is set well?

If you can not solve the problem, please contact our distributor.

Hanging mode

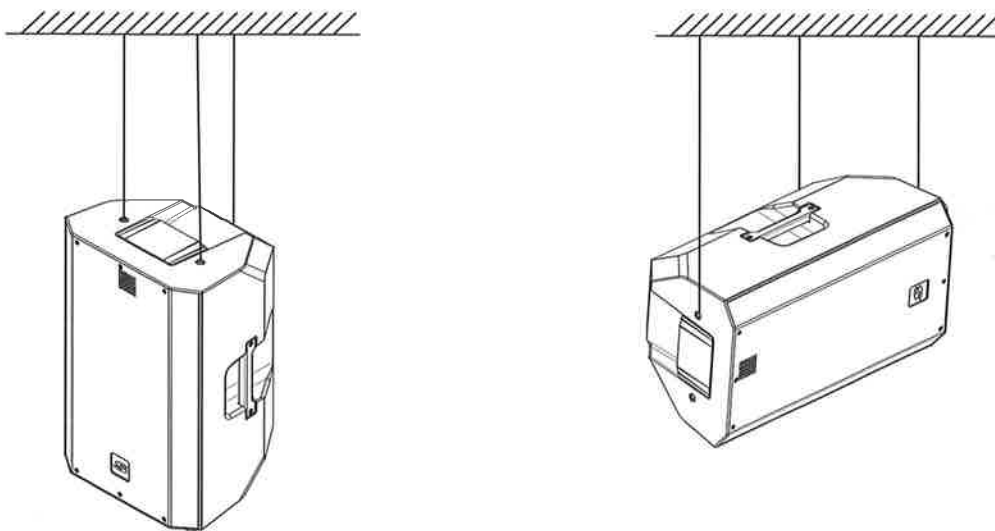

Connection Examples

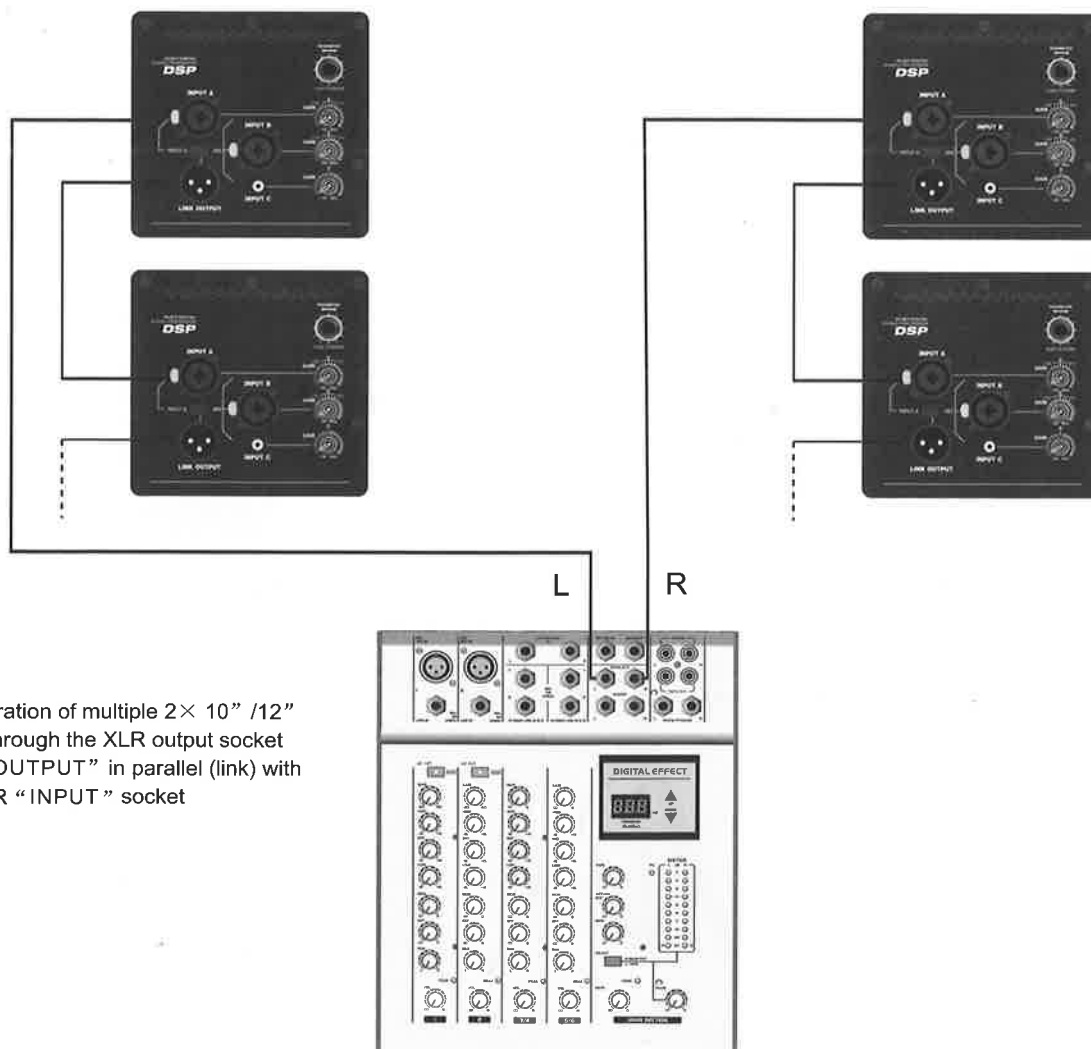

Configuration of multiple 2× 10” /12”
2-way through the XLR output socket
“LINK OUTPUT” in parallel (link) with
the XLR “INPUT” socket

Mixer

EXPECT THE BEST

*S*tudiomaster

**Unit 11,
Torc:MK
Chippenham Drive
Kingston
Milton Keynes
MK10 0BZ
United Kingdom.
Tel: +44(0)1908 281072 email: enquiries@studiomaster.com**